

Stationary placing boom

MXG 42-5

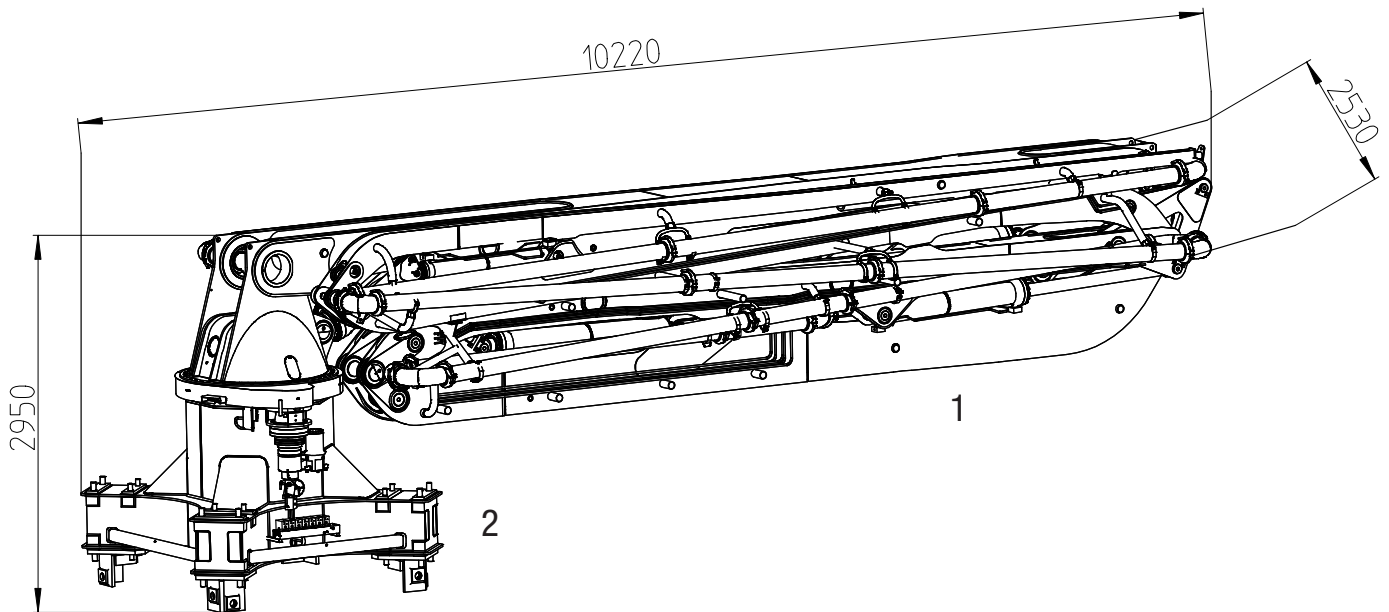

Description

- 1 5-section arm assembly with concrete line and end hose
- 2 Boom pedestal
- 3 Lattice tower (not included)

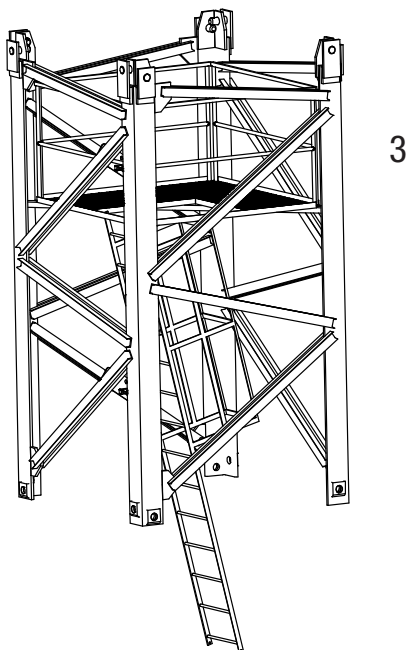

Reach information diagram

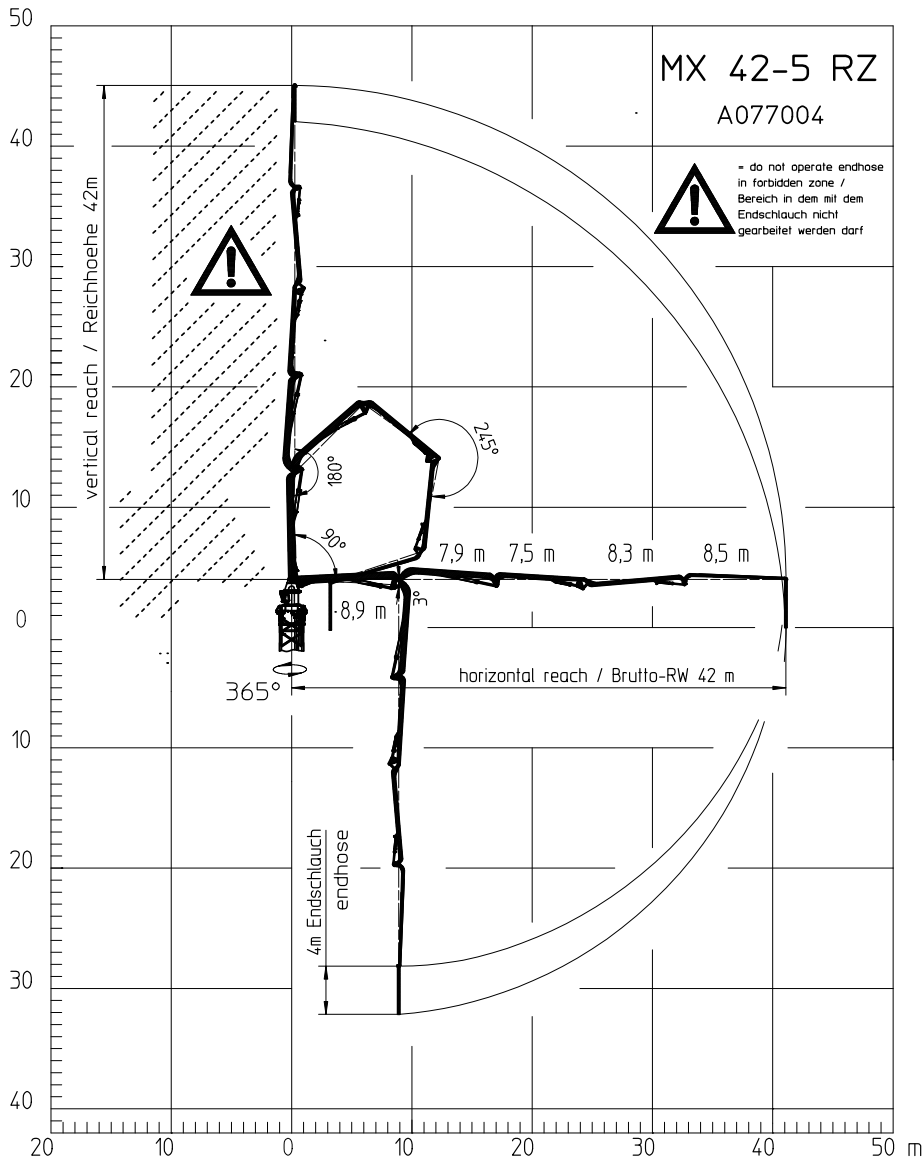

Technical data

Stationary placing boom		MXG 42-5
Sections		5
Reach height	m	42
Horizontal reach	m	42
Reach depth max.	m	32
Delivery line		DN 125
End hose length	m	4
Slewing range	°	365
Weight (boom + pedestal)	t	13



All data max. theor.

Range in which you must not work with the end hose.

Dimensions can differ depending on configuration.

Serial delivery scope

Arm assembly MXR 42-5	Radio remote control
Boom pedestal MXG 42-5 for lattice tower	Operating manuals (1× paper, 1× CD-ROM), spare part list
Delivery line DN 125	Painting: arm assembly RAL 5012 light blue
El.-hydraulic drive	Painting: base structure RAL 1015 light ivory
End hose 4.0m DN 125 5.5"	

See quotation for exact serial delivery scope.
Comprehensive range of options available on request.