

Stationary concrete pump

BSA 14000 HP D4

Output up to 84 m³/h
Delivery pressure up to 231 bar

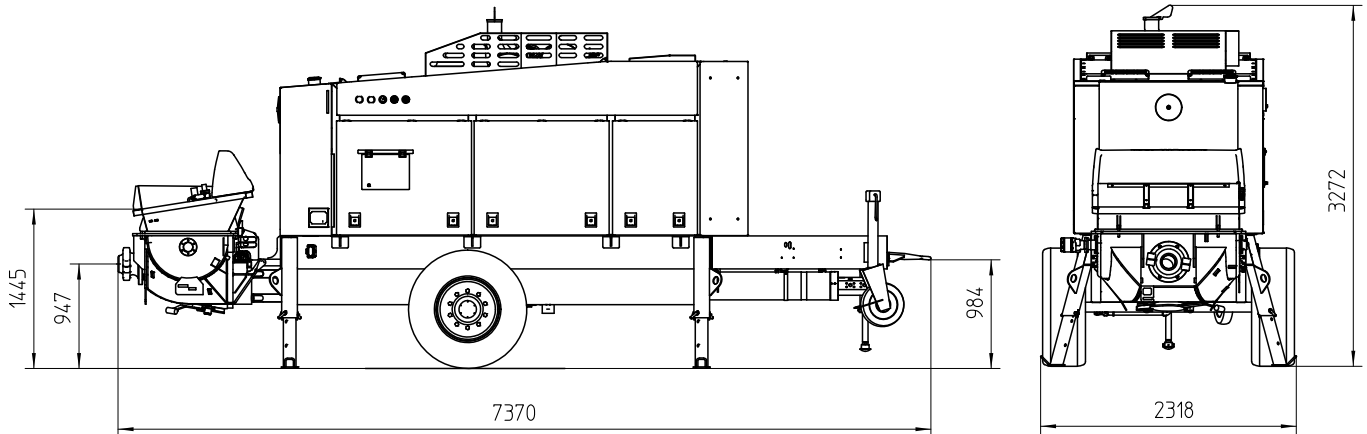

Note: Standard version BSA 14000 HP D4. Dimensions and weights depend on equipment. Subject to technical modifications and errors.

Technical data

| Model | | BSA 14000 HP D4 |
|----------------------|-------------------|-----------------|
| Material number | | 102485.000 |
| Output | m ³ /h | 84 / 57 * |
| Delivery pressure | bar | 158 / 231 * |
| Delivery cylinder | Ø mm | 180 |
| Delivery cyl. stroke | mm | 2100 |
| Strokes / minute | | 26 / 13 * |
| Engine power | kW | 470 |
| Hopper | | RS 905 HF |
| Capacity | l | 600 |
| Filling height | m | approx. 1.3 |
| Transfer tube | | S 1812 D |
| Line connection | mm | ZX 125 |
| Pressure connection | " | 8 |
| Control system | | EPS FFH |
| Weight | kg | 10800 |

* Values for hydraulic fluid being fed to piston-side
All data maximum theoretical

Serial equipment

| | |
|---|---|
| Agitator safety switch off | Flushing water pump |
| Balloon tyres incl. transport protection | 160 l/min 25 bar |
| Cable remote control 10 m | Gate valve connection |
| Central lubrication on hopper, electrical | Grill 60 mm |
| Cleaning accessories | Hard metal wear parts |
| Coloring: Pump, frame, roof and tank anthracite grey; cover chrome yellow | Operating manuals (1× paper, 1× CD-ROM) spare part list |
| Concrete hopper with agitator | Pump flow meter |
| Concrete output adjust, electrically | Set-up foot hydraulically |
| Concrete pressure adjust, electrically | Speed drawdown automatically on pump stop |
| Coupling ring (DIN) | Splash guard |
| Drive diesel, CAT 470 kW, Stage 4 | Square outriggers 4× mech. 15°-slange |
| Electronic error management | Tool set incl. standard equipment |
| Ergonic Graphic Display (EGD) | Trailer F8, can be driven on job site |

See quotation for exact serial delivery scope.
Comprehensive range of options available on request.