



Putzmeister

Stationary concrete pump

BSA 1005 D5 BSA 1005 E

Output up to 52 m³/h
Delivery pressure up to 70 bar

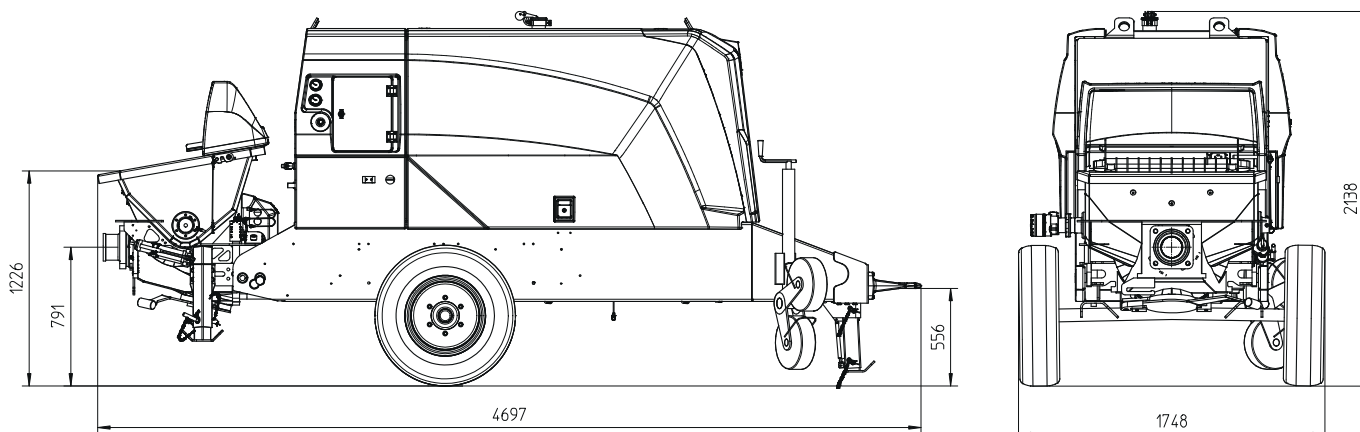

Dimensions and weights depend on equipment. Subject to technical modifications and errors.

Technical data

Model		BSA 1005 D5	BSA 1005 E
Material number		102682.000	102683.000
Output	m ³ /h	52	47
Delivery pressure	bar	70	
Delivery cylinder	Ø mm	180	
Delivery cyl. stroke	mm	1000	
Strokes / minute		33	31
Engine / motor power	kW	55.4	45
Hopper		RS 488	
Capacity	l	approx. 300	
Filling height	m	1.23	
Transfer tube		S 1812	
Line connection	mm	SK 125	
Pressure connection	"	5.5	
Control system		Ergonic 3.0	
Diesel tank	l	120	–
Weight	kg	2900	3100

Serial equipment

Agitator safety switch off	Flushing water pump 50 l/min 20 bar
Cable remote control 10 m	Grill 60 mm
Central lubrication on hopper with grease gun	Operating manuals (1× paper, 1× CD-ROM) spare part list
Chassis F8	Output adjustment, electrical
Cleaning accessories	Outriggers 3× mech.
Coloring: Pump, frame, roof anthracite-grey Doors chrome yellow	Speed drawdown automatically on pump stop (Diesel driven only)
Concrete hopper with agitator	Splash guard
Drawbar eye (DIN)	Support wheel
Drive diesel, Deutz 55.4 kW, Stage 5 (1005 D5)	Tool set incl. standard equipment
Drive electric, 45 kW, iE03 (1005 E)	
Electronic error management	
Ergonic Graphic Display	

All data maximum theoretical

See quotation for exact serial delivery scope.
Comprehensive range of options available on request.