

# PUMI®

# 25-4.67 CS

Truck-mounted concrete pump with mixer

CS transfer tube system

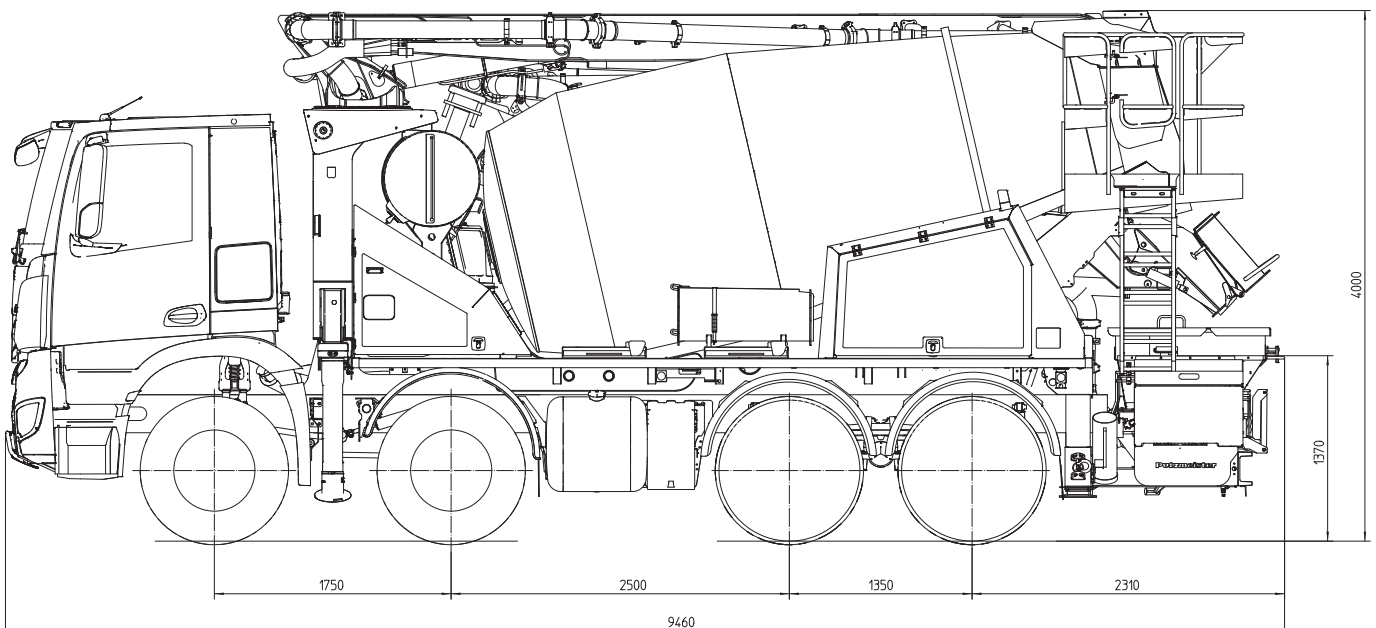

Note: Standard version. Subject to technical modifications and errors. Dimensions in mm, for example MB-Arocs, dimensions depending on the vehicle. Pictures contain optional equipments.

## Technical data

Boom TMM 25-4			
Number of arms			4
Reach height	m		24.5
Horizontal reach	gross	m	20.0
	net	m	17.3
Reach depth max.	m		13.6
Unfolding height	m		5.5
End hose length	m		3
Folding system			Z fold (Z)
Delivery line			DN 125 – 5.5

Pump TMP 60 CS			
Output	m <sup>3</sup> /h		56
Delivery pressure	bar		57
Delivery cylinder	Ø mm		230
Stroke	mm		700

Maximum outputs of 56 m<sup>3</sup>/h and maximum concrete pressures of 57 bar may be achieved, depending on the equipment of the machine.

It is not possible to achieve maximum outputs and maximum concrete pressures simultaneously.

All data maximum theoretical.

Truck mixer 7 cbm			
Nominal capacity	m <sup>3</sup>		7
Filling ratio	%		60
Drum speed	rpm		1 – 14
Water tank	l		630

## Reach information diagram

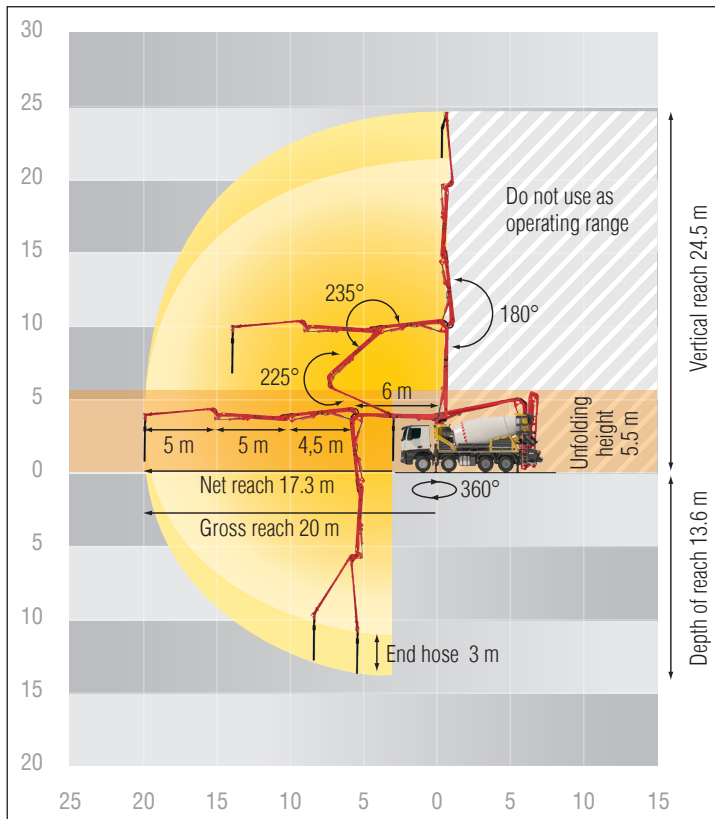

## Support

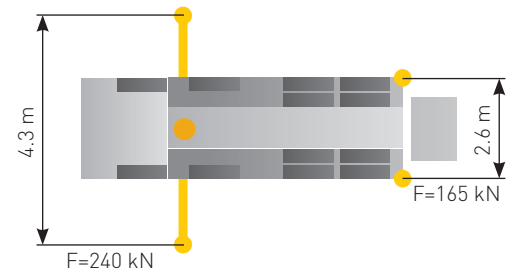

## Delivery scope Standard Line

Agitator radio remot/on site controlled	Delivery piston "long life"	Second drip ring on mixer drum
Agitator safety switch off (RFID)	Drawbar eye	Slewable and folding chute, steal
Box for sponge balls	EMC – Ergonic Mixer Control	Standard support system (incl. ESC)
Bracket for hammer and trowel	End hose 3m	Support plates 4x
Cardan shaft maintenance free	EOC – Ergonic Output Control	Tool set incl. standard equipment
Casted elbow with cleaning port	EPS – Ergonic Pump System	Wash-out port lid with slide pin
Central lubrication drum rollers, manual	ESC – Ergonic Setup System	Water supply mixer (remote/on site)
Central lubrication hinge first arm, manual	Lighting all control elements	Water tank 630 l, pressure tank
Central lubrication hopper, electrically	Lighting hopper, mounted	Water tap under water tank
Chute adjustment hydraulic-electrically	Lockable storage space	
Cleaning spray hose incl. bracket and spray nozzle	Mixer drum with 4 end spiral plates	
Compressed air connection rear side	Mudgard plastic	
Concrete hopper with agitator	Operating manuals (1x paper, 1x CD-ROM), spare part list	
Connection for watertank filling, right side	Paint: 4-color putzmeister standard	
Cover for hopper	Platform for cleaning with drop guard	
Delivery cylinder chromium plated	Radio remote control with display	
Delivery line (1-layer) PM40 DN125	Rubber collar on concrete hopper	
Delivery note-box		

See quotation for exact serial delivery scope.  
Comprehensive range of options available on request.