

**Putzmeister**

**PUMI®**

**21-3.67 Q**

Truck-mounted concrete pump with mixer

Rotor pump system

MN 101086.004

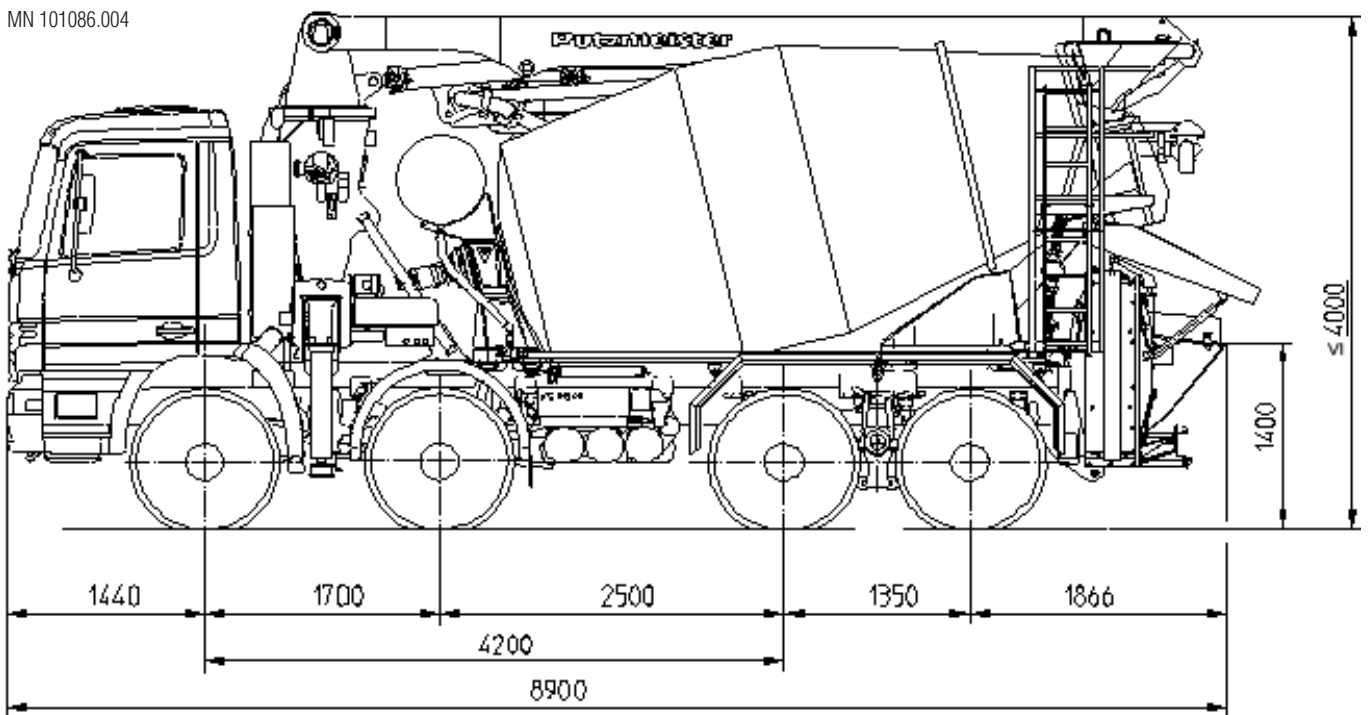

Note: Standard version. Dimensions and weights depend on boom, mixer and chassis.  
Dimensions in mm, MB-Actros as example, total height depends on the chassis.

## Technical data

Boom TMM 21-3		
Number of arms		3
Reach height	m	20.6
Horizontal reach	gross	m 16.9
	net	m 14.5
Reach depth max.	m	9.9
Unfolding height	m	5.6
End hose length	m	3
Folding system		Z fold (Z)
Delivery line		DN 100 – 4.5

Pump TMP 60 Q		
Output	m <sup>3</sup> /h	58
Delivery pressure	bar	25
Pumping hose	Ø mm	125

Maximum outputs of 58 m<sup>3</sup>/h and maximum concrete pressures of 25 bar may be achieved, depending on the equipment of the machine.

It is not possible to achieve maximum outputs and maximum concrete pressures simultaneously.

All data maximum theoretical.

Truck mixer 7 cbm		
Nominal capacity	m <sup>3</sup>	7
Total capacity	m <sup>3</sup>	11.5
Filling ratio	%	63
Power consumption	kW	52
Drum speed	rpm	1 - 14
Pressure tank for water	l	650

# Reach information diagram, Support, Transfer tube

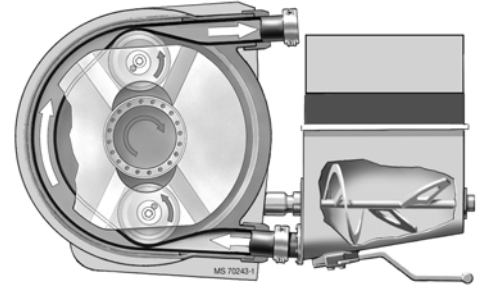
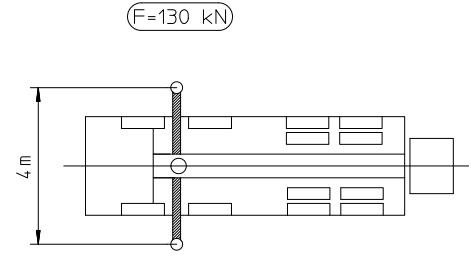
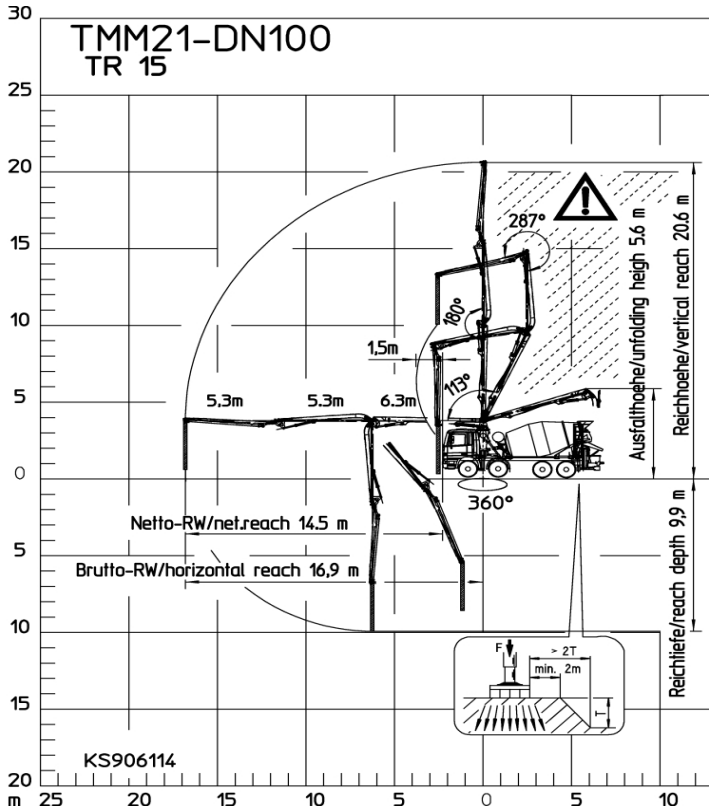

 Range in which you must not work with the end hose.

## Delivery scope

<b>Support</b>	Electric control box with display and ergonomic diag. interface	<b>Cleaning</b>
Support legs T 4	EOC (Ergonic output control)	High pressure water pump 100 bar with running dry connection
Support plates 2 x in magazine open	EPS (Ergonic pump system)	Cleaning hose with nozzle
<b>Illumination</b>	Information concrete stiffness on display	Bracket for hammer and cleaning brush
Hand working search light 1 x	Mixer control via chassis cabin with display	Cardan shaft maintenance free
Marker lamps lateral and rear side, EU	Mixer-comfort-functions through display radio remote	<b>Safety</b>
Working light for hopper illumination, mounted	<b>Delivery line</b>	Agitator safety switch off
<b>Extras</b>	Concrete line (1-layer) PM 36 (4,5"), armpack	Cleaning hose with nozzle
Operating manuals 2x (1xpaper, 1xCD-ROM) spare part list	End hose 3,0 m DN 100, 4,5"	Lateral underrun protection
Painting: mixer MB 1227 chrome yellow pump MB 1227 chrome yellow arm assembly RAL 3020 signalred	<b>Mixing drum</b>	Mudguard cpl. aluminium (bulb plate), rear axle
Tool set incl. standard equipment	Truck mixer 7 cbm	Underrun protection, rear side
Chassis horn operated in control box	Water tank 650 l, pressure tank	<b>Stowage Compartment</b>
Compressed air connection	Water tap under water tank	Hose bracket for 6 x DN 65 5 m for 4-axle
Towing eye	Watertank filling from both sides	Tool box plastic
Vacuum pump	EMC (Ergonic mixer control)	<b>Hopper</b>
<b>Remote control</b>	Chute adjustment hydraulic mechanically	Concrete hopper with agitator
Radio remote control fully prop. with display	Chute extension steel 1 x	Rubber collar on concrete hopper
Remote control CPC with 25 m cable	Ladder, telescopic	Central lubrication hopper, electrically
Control platform with display, rear side	Mixer discharge automatically	Level indicator
	Second drip ring on mixer drum	
	Wear plate on discharge hopper	
	Wear plate on inlet hopper	

See quotation for exact serial delivery scope.  
Comprehensive range of options available on request.